

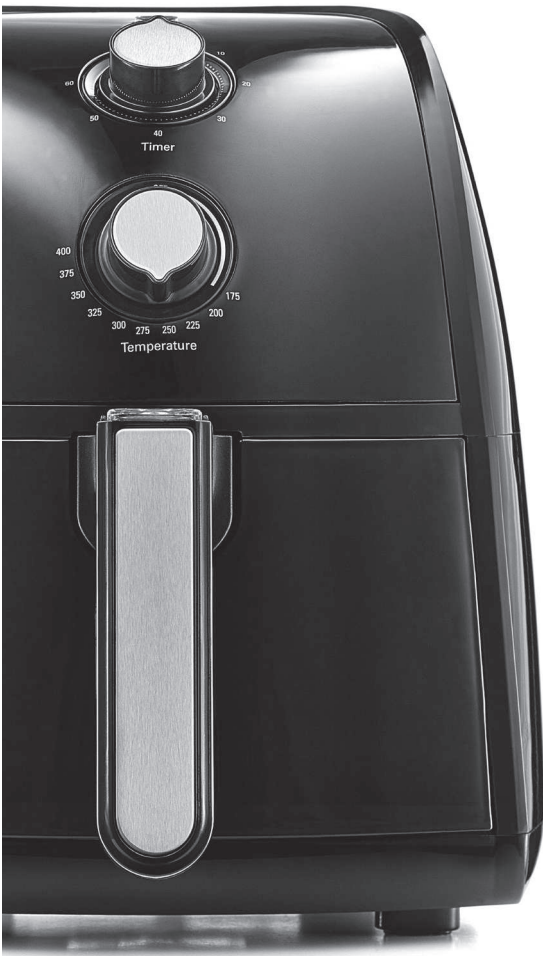

2.2lb AIR FRYER



Instruction Manual
Recipe Guide

Register your product and get support at:
www.bellahousewares.com/welcome

Table of Contents

Important Safeguards.....2
Additional Important Safeguards.....3
Notes on the Plug4
Notes on the Cord4
Plasticizer Warning.....4
Electric Power.....4
Getting to Know Your 2.2lb Air Fryer.....5
Control Dials.....6
Before Using for the First Time6
Operating Instructions.....7
Helpful Hints.....8
Air Frying Chart 8-9
User Maintenance Instructions.....10
Care & Cleaning Instructions10
Storing Instructions.....10
Recipe Guide 11-20
Warranty21

IMPORTANT SAFEGUARDS

When using electrical appliances, basic safety precautions should always be followed, including the following:

- 1. READ ALL INSTRUCTIONS.**
2. Do not touch hot surfaces. Use handles or knobs. Use oven mitts or potholders.
3. To protect against electric shock do not immerse cord, plugs, or appliance in water or other liquid.
4. This appliance is not intended for use by persons (including children) with reduced physical, sensory or mental capabilities, or lack of experience and knowledge, unless they have been given supervision or instruction concerning use of the appliance by a person responsible for their safety.
5. Children should be supervised to ensure that they do not play with the appliance.
6. Unplug from outlet when not in use and before cleaning. Allow to cool before putting on or taking off parts, and before cleaning the appliance.
7. Do not operate any appliance with a damaged cord or plug or after the appliance malfunctions, or has been damaged in any manner. Bring it to a qualified technician for examination, repair or electrical or mechanical adjustment.
8. The use of accessory attachments not recommended by the appliance manufacturer may cause injuries.
9. Do not use outdoors.
10. Do not let cord hang over edge of table or counter, or touch hot surfaces.
11. Do not place on or near a hot gas or electric burner, or in a heated oven.
12. Extreme caution must be used when moving an appliance containing hot oil or other hot liquids.
13. To disconnect, turn both the timer dial and temperature dial to OFF. Then remove plug from wall outlet.
14. Do not use appliance for other than intended use.
15. Make sure the frying basket is locked into the front of the drawer – both frying basket handle tabs must be fully inserted into the notches on the top of the basket drawer.
16. Always make sure frying basket drawer is fully closed, with frying basket handle locked securely in the drawer, while Air Fryer is in operation.
WARNING: Air Fryer will not operate unless frying basket drawer is fully closed.
CAUTION: After hot air frying, the frying basket and frying basket drawer and the cooked foods are hot. Extreme caution must be used when handling the hot Air Fryer basket/drawer.

FOR HOUSEHOLD USE ONLY

ADDITIONAL IMPORTANT SAFEGUARDS

CAUTION HOT SURFACES: This appliance generates heat and escaping steam during use. Proper precautions must be taken to prevent the risk of burns, fires, or other injury to persons or damage to property.

CAUTION: This appliance is hot during operation and retains heat for some time after turning OFF. Always use oven mitts when handling hot materials and allow metal parts to cool before cleaning. Do not place anything on top of the appliance while it is operating or while it is hot.

1. All users of this appliance must read and understand this instruction manual before operating or cleaning this appliance.
2. The cord to this appliance should be plugged into a 120V AC electrical outlet only.
3. If this appliance begins to malfunction during use, immediately unplug the cord. Do not use or attempt to repair the malfunctioning appliance.
4. Do not leave this appliance unattended during use.
5. Do not immerse power cord in any liquid. If the power cord to this appliance is damaged, it must be replaced by contacting Consumer Service.
6. Keep the cord out of reach from children and infants to avoid the risk of electric shock and choking.
7. Place the Air Fryer on a flat, heat-resistant work area.
8. Do not obstruct the air outlet or air inlets on the back and sides of the Air Fryer, with any objects. Avoid escaping steam from the air outlet during air frying.
9. Keep appliance at least 4 inches away from walls or other objects during operation.
10. Always use the frying basket handle to open frying basket drawer.
11. Do not replace the empty frying basket drawer (without the frying basket) into the Air Fryer body. Check to make sure the frying basket is locked in position in the drawer.
WARNING: After air frying, make sure to place the frying basket drawer on a flat, heat-resistant surface before pressing the basket release button.
WARNING: Under- or over-filling the frying basket may damage the Air Fryer and could result in serious personal injury.
12. Never move a hot Air Fryer or an Air Fryer containing hot food. Allow to cool before moving.

SAVE THESE INSTRUCTIONS

NOTES ON THE PLUG

This appliance has a polarized plug (one blade is wider than the other). To reduce the risk of electric shock, this plug will fit in a polarized outlet only one way. If the plug does not fit fully into the outlet, reverse the plug. If it still does not fit, contact a qualified electrician. Do not modify the plug in any way.

NOTES ON THE CORD

The provided short power-supply cord (or detachable power-supply cord) should be used to reduce the risk resulting from becoming entangled in or tripping over a longer cord. An extension cord is not recommended for use with this product. Always plug directly into a wall outlet/receptacle.

PLASTICIZER WARNING

CAUTION: To prevent Plasticizers from migrating to the finish of the counter top or table top or other furniture, place NON-PLASTIC coasters or place mats between the appliance and the finish of the counter top or table top. Failure to do so may cause the finish to darken; permanent blemishes may occur or stains can appear.

ELECTRIC POWER

If the electrical circuit is overloaded with other appliances, your appliance may not operate properly. It should be operated on a separate electrical circuit from other appliances.

Getting to Know Your Air Fryer

Product may vary slightly from illustration

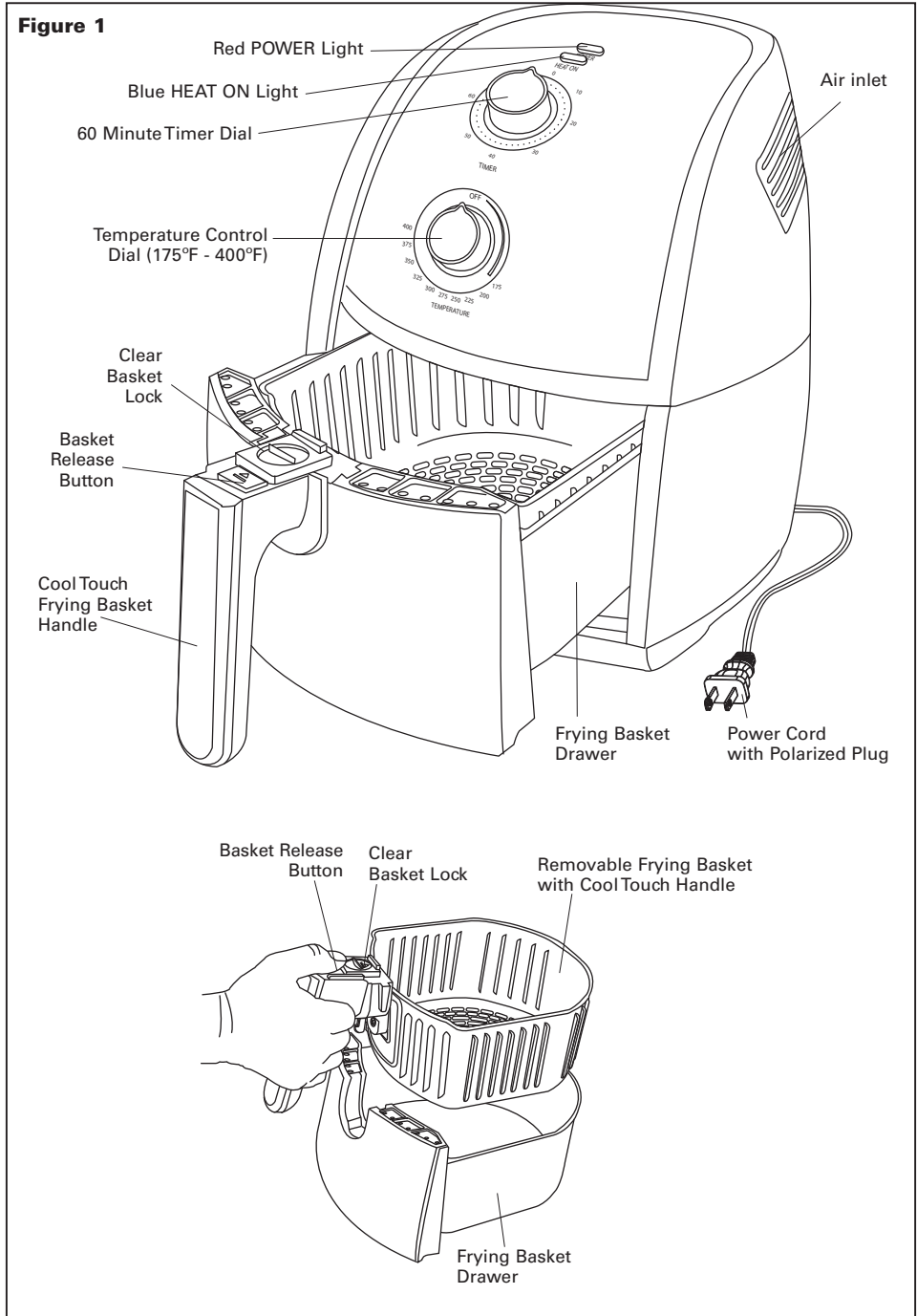

Control Dials

Temperature Control Dial

- Select air frying temperatures from 175°F to 400°F. Temperatures can be adjusted at any time.
- The blue HEAT ON light will turn off once the set temperature is reached.
- The blue HEAT ON light and heating element cycle on and off to maintain the selected temperature.

60 Minute Countdown Timer Dial

- Once the timer dial is set, the red POWER light will illuminate to show the Air Fryer is powered on.
- To assure even cooking/browning, open the frying basket drawer halfway through the cooking time. Check, turn or vigorously shake foods in the frying basket.

IMPORTANT: When you pull the drawer out from the Air Fryer body, the red POWER light and the Air Fryer will turn OFF. The timer will continue to count down when the drawer is opened.

- Heating will resume when the drawer is replaced.
- One beep will sound when the set air frying time has reached 0. The Air Fryer will turn OFF automatically. Both the red POWER light and the blue HEAT ON light will turn off.

IMPORTANT: When all air frying is finished, turn both the temperature control dial and the timer dial to 0 (OFF). Unplug the Air Fryer when not in use.

Before Using for the First Time

1. Your Air Fryer is shipped with the frying basket locked into the drawer, inside the Air Fryer body. Firmly grasp the frying basket handle to open frying basket drawer; then remove the drawer from the machine and place on a flat, clean work area.

2. **To unlock and remove the frying basket from the drawer:**
slide the clear basket lock forward to expose the basket release button. Press the basket release button with your thumb while pulling the frying basket straight up and out of the drawer. Refer to Figure 2.

3. Remove all packing material and labels from the inside and outside of the Air Fryer. Check that there is no packaging underneath and around the frying basket and drawer.

4. Wash frying basket and drawer in hot, soapy water.

5. **DO NOT IMMERSE THE AIR FRYER BODY IN WATER.** Wipe Air Fryer body with a damp cloth. Dry all parts thoroughly.

6. **Lock the clean frying basket into the drawer.** There are 2 tabs on each side of the handle. Slide the 2 handle tabs into the notches on the top of the basket drawer. An audible click can be heard as the frying basket handle locks securely into place. Refer to Figure 3.

IMPORTANT: Slide the clear basket lock back over the basket release button to prevent accidental frying basket release.

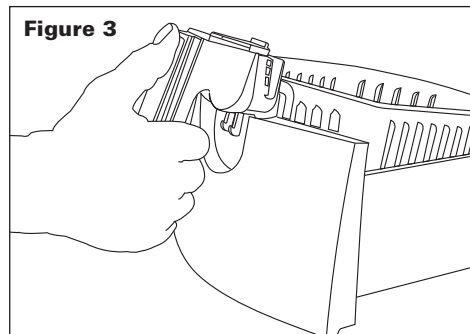
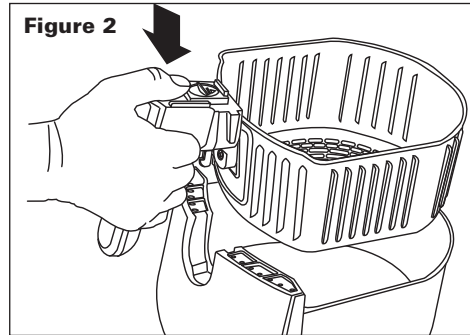

Operating Instructions

WARNING! This unit should not be used to boil water.

NOTE: During first use, the Air Fryer may emit a slight odor. This is normal.

1. Place the Air Fryer on a flat, heat-resistant work area, close to an electrical outlet.
2. Firmly grasp the frying basket handle to open frying basket drawer; then remove the drawer from the machine and place on a flat, clean surface.
3. Place food into the frying basket. Do not overfill frying basket with food. To ensure proper cooking and air circulation, NEVER fill any frying basket more than 2/3 full. When air frying fresh vegetables, we do not recommend adding more than 3 cups of food to the frying basket.
4. Insert the assembled frying basket drawer into the front of the Air Fryer. Always make sure frying basket drawer is fully closed.
5. Plug cord in the wall outlet.
6. Select air frying temperature from 175°F to 400°F.
7. Turn timer dial to the desired air frying time plus 3 minutes for preheat if the Air Fryer is cold. The blue HEAT ON light and the red POWER light will illuminate; the Air Fryer will begin heating.

IMPORTANT: The Air Fryer will not heat if the timer dial has not been set.

WARNING: Air Fryer will not heat -- the red POWER light will remain off, until frying basket drawer is fully closed.

8. The blue HEAT ON light will turn off when set temperature is reached.
NOTE: During air frying, the blue HEAT ON light will cycle on and off as proper air frying temperature is maintained.
9. To assure even cooking/browning, open the basket drawer halfway through the cooking time and check. Lift frying basket from frying basket drawer in order to turn or shake foods in the frying basket. Once complete, return the frying basket into frying basket drawer. Adjust temperature if needed. The timer will continue to count down when the drawer is opened, but the Air Fryer will stop heating until the drawer is replaced.

CAUTION: Make sure the clear basket lock is in the locked position when shaking foods for the Air Fryer. To avoid damage to persons or personal property, do not press the basket release button while shaking the frying basket.

WARNING: Extreme caution must be used when handling the hot frying basket and drawer. Avoid escaping steam from the frying basket and the food.

CAUTION: Always use oven mitts when handling the hot air fryer basket.

CAUTION: Hot oil can collect at the base of the drawer. To avoid risk of burns or personal injury, or to avoid oil from contaminating air fried foods, always unlock and remove the frying basket from the drawer before emptying. NEVER turn the drawer upside down with the frying basket attached.

NOTE: The Air Fryer can be turned OFF at any time by turning the timer dial to 0.

10. One beep will sound when the set air frying time has expired. The Air Fryer will turn OFF automatically. Both the red POWER light and the blue HEAT ON light will turn off.
11. Shake the frying basket/drawer vigorously and check food for browning and doneness. If additional air frying is needed, adjust temperature if desired, and set timer for 5 minute increments until fully cooked.
12. Allow cooked food to rest for 5 to 10 seconds before removing basket drawer from Air Fryer or food from frying basket.
13. When air frying is finished, remove the drawer from the machine and place on a flat, heat resistant surface. Then remove frying basket from the drawer.
14. Shake air fried foods out onto serving area. Promptly return the frying basket to the drawer and lock into place. Continue with subsequent batches, if any.
NOTE: When the next batch is ready, the Air Fryer's 1500 watt heating system will quickly heat and recover.
15. When all air frying is completed, turn both the temperature control dial and the timer dial to 0 (OFF). Both the red POWER light and the blue HEAT ON light will turn off.
16. Unplug the Air Fryer when not in use.

Helpful Hints

1. Olive oil spray or vegetable oil works well for air frying.
2. Use your Air Fryer to cook pre-packaged foods with a fraction of the oil, in a fraction of the time! As a general rule, lower the recipe baking temperature by 50°F and reduce the cooking time by 30% to 50% depending on the food and amount.
3. Do not overfill frying basket with food. NEVER fill any frying basket more than 2/3 full. When air frying fresh vegetables, we do not recommend adding more than 3 cups of food to the frying basket.
4. **For best results**, some foods need to be shaken vigorously or turned over during the air fry time. Consult the Air Frying Chart following as a general guide.
5. To avoid excess smoke, when cooking naturally high fat foods, such as chicken wings or sausages, it may be necessary to empty fat from the frying basket drawer between batches.
6. Always pat food dry before cooking to encourage browning and avoid excess smoke.
7. Air fry small batches of freshly breaded foods. Press breading onto food to help it adhere. Arrange in frying basket so that food is not touching to allow air flow on all surfaces.
8. The Air Fryer can be used to reheat food. Set the temperature to 300°F for up to 10 minutes.

Air Frying Chart

WARNING! ALWAYS USE A MEAT THERMOMETER TO ENSURE THAT MEAT, POULTRY AND FISH ARE COOKED THOROUGHLY BEFORE EATING. The following chart is intended as a guide only. The quantity of food air fried at one time, the thickness or density of the food, and whether the food is fresh, thawed, or frozen may alter the total cooking time necessary.

1. To assure even cooking/browning, open the frying basket drawer halfway through the cooking time. Check, turn or vigorously shake foods in the frying basket. This chart lists average total air frying time, the time at which some action is required, and what action is to be taken for best results.
2. Remember, frying smaller batches will result in shorter cooking times and higher food quality. Adjust air frying temperatures and times as necessary to suit your taste.

IMPORTANT NOTE: Unless food is pre-packaged and pre-oiled, for browned and crispy results, all foods should be lightly oiled before air frying.

- Oil may be sprayed or brushed onto foods.
- Spray oils work well as oil is evenly distributed and smaller quantities of oil are needed.
- To ensure crispy results, make sure foods are dried before adding oil.
- Cut pieces smaller to create more surface area for crispier results.
- Blanching is a term that refers to pre-cooking foods at a lower temperature before the final air fry.
- Add 3 minutes to the AIR FRY TIME to allow the Air Fryer to preheat.

FOOD	TEMP	AIR FRY TIME*	TIME	ACTION
Mixed Vegetables (roasted)	400°F	15 - 20 minutes	8 minutes	shake
Broccoli (roasted)	400°F	15 - 20 minutes	8 minutes	shake
Onion Rings (frozen)	400°F	12 - 18 minutes	8 minutes	shake
Cheese Sticks (frozen)	350°F	8 - 12 minutes	—	—
Fried Sweet Potato Chips (fresh, hand cut, 1/8 to 1/16-in. thick)				
Blanch (Step 1)	325°F	15 minutes	8 minutes	shake
Air Fry (Step 2)	350°F	10 - 15 minutes	5 minutes	shake
French Fries, (fresh, hand cut, 1/4 to 1/3-in. thick)				
Blanch (Step 1)	325°F	15 minutes	8 minutes	shake
Air Fry (Step 2)	350°F	10 - 15 minutes	5 minutes	shake
French Fries, thin (frozen) 3 cups	400°F	12 - 16 minutes	8 minutes	shake
French Fries, thick (frozen) 3 cups	400°F	17 - 21 minutes	10 minutes	shake
Meatloaf, 1 lb.	350°F	35 - 40 minutes	—	—
Hamburgers, 1/4 lb. (up to 4)	350°F	10 - 14 minutes	(rare to well done)	—
Hot Dogs/Sausages	350°F	10 - 15 minutes	6 minutes	turn over
Chicken Wings (fresh/thawed), Blanch (Step 1)	325°F	15 minutes	8 minutes	shake
Air Fry (Step 2)	350°F	10 minutes	5 minutes	shake
Chicken Tenders/Fingers, Blanch (Step 1)	350°F	13 minutes	13 minutes	turn over
Air Fry (Step 2)	400°F	5 minutes	3 minutes	shake
Chicken Pieces	350°F	20 - 30 minutes	10 minutes	turn over
Chicken Nuggets (frozen)	350°F	10 - 15 minutes	5 minutes	shake
Catfish Fingers (thawed, battered)	400°F	10 - 15 minutes	5 minutes	turn over
Fish Sticks (frozen)	400°F	10 - 15 minutes	5 minutes	turn over
Apple Turnovers	400°F	10 minutes	—	—
Donuts	350°F	8 minutes	4 minutes	turn over
Fried Cookies	350°F	8 minutes	4 minutes	turn over

*Add 3 minutes to the AIR FRY TIME to allow the Air Fryer to preheat.

PLEASE NOTE:

The USDA recommends that meats such as beef and lamb, etc. should be cooked to an internal temperature of 145°F/63°C. Pork should be cooked to an internal temperature of 160°F/71°C and poultry products should be cooked to an internal temperature of 170°F/77°C - 180°F/82°C to be sure any harmful bacteria has been killed. When reheating meat/poultry products, they should also be cooked to an internal temperature of 165°F/74°C

User Maintenance Instructions

This appliance requires little maintenance. It contains no user-serviceable parts. Any servicing requiring disassembly other than cleaning must be performed by a qualified appliance repair technician.

Care & Cleaning Instructions

WARNING! Allow the Air Fryer to cool fully before cleaning.

1. Unplug the Air Fryer. Remove frying basket from the drawer. Make sure the frying basket drawer and frying basket have cooled completely before cleaning.
2. Wash the basket drawer and frying basket in hot soapy water. Do not use metal kitchen utensils or abrasive cleansers or cleaning products as this may damage the non-stick coating.
3. The frying basket and frying basket drawer are dishwasher-safe. For best results, place in the top rack of your dishwasher to clean.
4. Wipe the Air Fryer body with a soft, non-abrasive damp cloth to clean.

Storing Instructions

1. Make sure the Air Fryer is unplugged and all parts are clean and dry before storing.
2. Never store the Air Fryer while it is hot or wet.
3. Store Air Fryer in its box or in a clean, dry place.

Recipes

Stuffed Eggplant Boats

Serves 4

- 2 (6-inch) eggplants
 - 2 tablespoons salt
 - 1/3 cup chopped onions
 - 6 oz. Italian sausage, bulk or casing removed
 - 1/2 cup Italian tomato sauce
 - 2 cloves garlic, minced
 - 1 cup shredded mozzarella
 - 2 tablespoons Parmesan cheese
 - 2 tablespoons olive oil
 - Kosher salt
 - fresh ground black pepper to taste
1. **Cut tops off eggplants; then slice in half horizontally.**
 2. **Scoop flesh from eggplants halves to make boats. Chop insides into small 1/4" pieces and place in colander over a plate or in the sink.**
 3. **Salt eggplant pieces. Salt eggplant halves (boats) and place cut side down in colander. Allow eggplant to drain for 40 minutes to 2 hours.**
 4. **Rinse pieces and each eggplant boat under cold water.**
 5. **Prepare filling: Sauté onions and sausage until golden brown. Add tomato sauce, eggplant pieces and garlic. Simmer for 20 minutes.**
 6. **Allow stuffing to cool. Add mozzarella and mix well.**
 7. **Place 4 eggplant shells into the basket.**
 8. **Set Air Fryer to 350° and air fry for 15 minutes.**
 9. **Remove par-cooked eggplant boats. Brush insides with olive oil and sprinkle salt and pepper to taste.**
 10. **Stuff eggplant boats and top with Parmesan cheese.**
 11. **Add 2 stuffed eggplant boats to the frying basket.**
 12. **Set Air Fryer to 400° and air fry for 10 minutes.**
 13. **Check eggplant with a fork. Remove cooked eggplant boats from frying basket, or replace frying basket and set timer to air fry for 5 minute intervals until fully cooked.**
 14. **Repeat with 2 remaining stuffed boats.**

Recipes

Stuffed Chicken Breasts

Serves 3

- 3 large skinless, boneless chicken breasts, pounded
 - 1/2 box (3 oz.) Stove Top® (or any boxed stuffing mix)
 - 1/2 cup water
 - 1 egg, beaten
 - seasoned salt, to taste
 - garlic salt, to taste
 - freshly ground black pepper, to taste
1. **Place chicken breast between 2 pieces of plastic wrap. To prevent shredding, add a small splatter of water between the chicken and the wrap. Pound the thickest parts of the chicken breasts and flatten to a consistent 1/4- to 3/8-inch thickness.**
 2. **In a medium mixing bowl, add stuffing mix and water. Let stuffing stand for 5 minutes. Add beaten egg and mix well.**
 3. **Add 1/2 cup stuffing to the center of each chicken breast.**
 4. **Roll each breast and place seam side down into the frying basket.**
 5. **Sprinkle seasoned salt, garlic salt and black pepper over the tops of each rolled chicken breast.**
 6. **Set Air Fryer to 350° and air fry for 20 -25 minutes.**
 7. **An audible beep can be heard when the air frying time has expired. Cut a slit into the thickest piece of chicken to test doneness. When done, juices should run clear.**
NOTE: Air frying times may vary based on size and thickness of chicken breast.
 8. **Remove cooked chicken breasts from frying basket, or replace frying basket and set timer to air fry for 5 minute intervals until fully cooked.**

Recipes

Air Fried Bacon Topped Meatloaf

- 1 lb. ground beef, 80/20
- 2/3 cup Italian bread crumbs
- 1/4 cup ketchup
- 1 teaspoon salt
- 1 teaspoon pepper
- 1 tablespoon dried onion
- 1 egg, beaten
- 2 strips thin sliced bacon
- barbeque sauce of your choice

1. **Combine meatloaf ingredients in a medium mixing bowl.**
2. **Shape into a 6" loaf.**
3. **Add to frying basket.**
9. **Set Air Fryer to 350° and air fry for 20 minutes.**
4. **An audible beep can be heard when the air frying time has expired.**
5. **Cut bacon strips in half and add to top of meatloaf. Brush with your favorite barbeque sauce. Replace frying basket.**
6. **Set timer to air fry for 15 minutes.**
7. **Test meatloaf for doneness. Remove from frying basket, or replace frying basket and set timer to air fry for 5 minute intervals until fully cooked.**

Francheezie Sliders

Makes: 12 Sliders

- 6 rashers bacon
 - 4 hot dogs
 - 1/4 cup shredded cheddar cheese
 - 12 Hawaiian dinner rolls
 - Cut each hot dog into 3 equal pieces. Cut each rasher of bacon in half.
1. **Cut each hot dog into 3 equal pieces. Cut each rasher of bacon in half.**
 2. **Split tops of hot dogs and pull slightly to open.**
 3. **Add a pinch of shredded cheddar cheese. Wrap in 1/2 piece of bacon.**
 4. **Set Air Fryer to 350° and air fry for 15 minutes.**

Recipes

Air Fried Sweet Potato Chips

- 1 large sweet potato
 - 2 teaspoons vegetable oil
 - cinnamon sugar or brown sugar, optional
1. **Wash the sweet potato and peel if desired.**
 2. **If available, use a mandolin to cut thin and even potato chips.**
 3. **To cut by hand, first cut potato in half, and with the flat side on the cutting board, hand cut into very thin chips.**
 4. **Place vegetable oil into a large bowl. Add raw potatoes and use your hands to mix well, making sure every chip is oiled on all sides.**
 5. **Transfer oiled chips to the frying basket.**
 6. **Set Air Fryer to 325°F and air fry for 15 minutes. Shake the frying basket/drawer vigorously halfway through air fry time.**
 7. **Increase heat to 350°F and air fry for 10 minutes. Shake the frying basket/drawer vigorously halfway through air fry time.**
 8. **Remove from Air Fryer. Sprinkle hot potatoes with cinnamon sugar or brown sugar for a special sweet treat.**

Recipes

Air Fried Chicken Tenders

- 1 -1-1/4 lb. chicken tenders
(8 tenders per package)
 - 1 tablespoon mayonnaise
 - 1 tablespoon honey mustard
 - 1/2 – 3/4 cup panko
bread crumbs, seasoned
 - Spray olive oil
1. Use chicken tenders whole or cut 8 chicken tenders into pieces.
 2. Set up 2-bowl breading station:
 - Add mayonnaise and honey mustard to a small bowl. Mix well.
 - Add bread crumbs to a plate; place it next to the mayonnaise bowl.
 3. Working one piece at a time, use a brush or knife to apply honey mustard on both sides of the chicken. Dip and use a fork to press and coat both sides with panko bread crumbs.
 4. Add 4 breaded chicken tenders (half the chicken) to the air frying basket.
Allow air circulation on all sides of each chicken piece for best browning.
 5. Spray with olive oil. (optional)
 6. Set Air Fryer to 350°F and air fry for 12 minutes. Turn chicken at 6 minutes.
 7. Set Air Fryer to 400°F and continue to air fry for 6 minutes. Turn chicken at 3 minutes.
 8. Repeat with remaining chicken.

Recipes

Fish & Chips

Fried Catfish Nuggets

Makes 12 nuggets

Serves 3 to 4

Treat your family to a delicious Fish & Chips dinner. These sweet and juicy catfish nuggets are crunchy good and pair fabulously with fresh hand cut French fries (recipe follows). Serve with fresh slaw and the meal is complete!

- 1 catfish filet
- 1/2 cup flour
- 1 tablespoon Old Bay® seasoning
- 1 egg + 1 egg white
- 1 cup seasoned panko bread crumbs
- olive oil spray

1. **Cut the catfish into strips approximately 1-inch by 2.5-inches in length.**
2. **Season each piece of fish, top and bottom, with Old Bay® seasoning.**
3. **Set up 3-bowl breading station:**
 - Flour
 - Whisk egg and egg white until well blended
 - Panko bread crumbs
4. **Place each piece of catfish into the flour.**
Pat gently with your hands to remove any excess.
5. **Dip both sides into egg.**
6. **Dip and use a fork to press and coat both sides with panko bread crumbs.**
7. **Add 4 to 6 pieces to air frying basket.**
Allow air circulation on all sides of each fish piece for best browning.
8. **Spray with olive oil. (optional)**
9. **Set Air Fryer to 400°F and air fry for 8 to 10 minutes. Turn fish at 5 minutes.**
10. **Repeat with remaining fish.**

Recipes

Chips (Fresh Hand Cut French Fries)

Serves 3 to 4

- 2 russet potatoes
- 4 teaspoons vegetable oil
- Kosher salt, to taste

Brine

- 6 to 8 cups water
- 4 tablespoons salt

1. **Cut potatoes into 1/4" x 1/4" French fries. Two medium potatoes will yield 4 cups raw cut potatoes. It is best to fry in 2 batches.**
2. **Soak potatoes in brine for 1 hour to overnight.**
3. **Dry on clean kitchen towel.**
4. **Place 4 teaspoons of vegetable oil into a large bowl. Add raw potatoes and use your hands to mix well, making sure every potato is oiled on all sides.**
5. **Transfer oiled potatoes to the frying basket.**
6. **Set Air Fryer to 325°F and air fry for 15 minutes. Shake the frying basket/drawer vigorously halfway through air fry time.**
7. **Increase heat to 350°F and air fry for 10 minutes. Shake the frying basket/drawer vigorously halfway through air fry time.**
8. **Remove from Air Fryer and add Kosher salt, or your choice of seasonings, to taste.**
9. **Repeat with remaining potatoes.**

Recipes

Air Fried Chicken Wings 2 Ways

- 6 fresh or frozen (thawed) chicken wings
- olive oil spray

Brine

- 2 cups water
- 1/4 cup Ponzu
- 1 tangerine (may substitute orange or any citrus)

1. Trim chicken wings into drumettes, flats, tips.
HINT: Save/Freeze wing tips for soups or stocks for later use.
2. Add chicken and brine to a bowl or resalable container. Refrigerate for 1 hour to overnight.
3. Drain chicken wings and discard brine.
4. Place wings on a clean kitchen towel and wrap to dry.

Naked Air Fried Chicken Wings

5. Set Air Fryer to 325°F and air fry for 15 minutes. Turn wings over.
6. Increase temperature to 350°F for 10 minutes.

Breaded Air Fried Chicken Wings

7. Set up 3-bowl breading station:
 - Add Old Bay® seasoning to flour
 - Whisk egg and egg white until well blended
 - Add panko bread crumbs
8. Place each wing piece into the flour.
Pat gently with your hands to remove any excess.
9. Dip both sides into egg.
10. Dip and use a fork to press and coat both sides with panko bread crumbs.
11. Add to air frying basket.
12. Spray with olive oil.
13. Set Air Fryer to 325°F and air fry for 15 minutes. Turn wings over.
14. Increase temperature to 350°F for 10 minutes.

Recipes

Apple Turnovers with Vanilla Drizzle

Makes 6 large turnovers

- 1 frozen, prepared puff pastry sheet, thawed
- 3/4 cups apple pie filling (or any prepared flavor of your choice)
- 1/2 teaspoon cinnamon
- 3 teaspoons golden raisins (optional)

Vanilla* Drizzle

- 1/2 cup confectioner's sugar
- 1 tablespoon milk
- 1/4 teaspoon vanilla* extract

Chocolate Drizzle

- 1/2 cup confectioner's sugar
- 2 tablespoons cocoa powder (unsweetened)
- 1 tablespoon milk
- 1/4 teaspoon vanilla* extract

1. Prepare icings to drizzle on turnovers. Combine ingredients in a small bowl and mix well.
**May substitute caramel, maple, almond, lemon, or orange extract.*
1. Unfold thawed puff pastry sheet onto a lightly floured surface.
2. Using a sharp knife, cut puff pastry sheet down the middle, and then into thirds to make 6 (5-in. x 5-in.) squares.
3. Spoon 2 tablespoons filling into the center of each square.
4. Fold pastry over the filling to form a triangle. Crimp edges with a fork to seal.
Add 2 large turnovers to the frying basket.
5. Set Air Fryer to 400° and air fry for 10 minutes.
6. Remove turnover from frying basket. Allow to cool.
7. Repeat with 4 remaining turnovers.
8. Use a small spoon to drizzle vanilla in a zig zag pattern over the top.
**May substitute any flavor prepared canned pie filling.*

Variation: Cherry Turnovers with Chocolate Drizzle

1. Follow the turnover recipe above. Use cherry pie filling.
2. Drizzle with chocolate icing.
3. Serve warm turnovers topped with your favorite ice cream.

Recipes

Air Fried Oreos

- 1 pack pre-made (refrigerated) buttermilk biscuits
 - 16 Oreo® cookies (or any other sandwich cookie of your choice)
 - cinnamon sugar
1. Flatten biscuit dough with your hands and stretch to fit around cookie.
NOTE: If you are using "Jumbo" or "Grand" sized dough, you may get 2 cookies per pre-cut biscuit.
 2. Sprinkle outstretched dough with cinnamon sugar.
 3. Add one cookie to the middle of the dough and wrap dough to encase.
 4. Set Air Fryer to 350°F and air fry for 8 minutes. Turn cookies over at 4 minutes.

Air Fried Donuts and Donut Holes

- 1 can pre-made (refrigerated) buttermilk biscuits
- cinnamon sugar or powdered sugar
- jelly, jam, fruit preserves of your choice

Plain (unfilled) donuts:

1. Use an overturned glass or cookie cutter to make donuts out of biscuit dough. Use a small cap or hand cut the center hole.

Filled donuts:

2. On a clean working surface, stretch dough and add 1 teaspoon filling. Encase the filling and shape into a slightly flattened ball.
3. Set Air Fryer to 350°F and air fry for 8 minutes. Turn donuts over at 4 minutes.
4. Sprinkle warm donuts with sugar and serve fresh donuts warm out of the frying basket.
5. If desired, prepare vanillia and/or chocolate drizzle and add to warm, freshly air fried donuts.



Limited TWO-YEAR Warranty

SENSIO Inc. hereby warrants that for a period of **TWO YEARS** from the date of purchase, this product will be free from mechanical defects in material and workmanship, and for 90 days in respect to non-mechanical parts. At its sole discretion, SENSIO Inc. will either repair or replace the product found to be defective, or issue a refund on the product during the warranty period.

The warranty is only valid for the original retail purchaser from the date of initial retail purchase and is not transferable. Keep the original sales receipt, as proof of purchase is required to obtain warranty validation. Retail stores selling this product do not have the right to alter, modify, or in any way revise the terms and conditions of the warranty.

EXCLUSIONS:

The warranty does not cover normal wear of parts or damage resulting from any of the following: negligent use of the product, use of improper voltage or current, improper routine maintenance, use contrary to the operating instructions, disassembly, repair, or alteration by anyone other than qualified SENSIO Inc. personnel. Also, the warranty does not cover Acts of God such as fire, floods, hurricanes, or tornadoes.

SENSIO Inc. shall not be liable for any incidental or consequential damages caused by the breach of any express or implied warranty. Apart from the extent prohibited by applicable law, any implied warranty of merchantability or fitness for a particular purpose is limited in time to the duration of the warranty. Some states, provinces or jurisdictions do not allow the exclusion or limitation of incidental or consequential damages, or limitations on how long an implied warranty lasts, and therefore, the above exclusions or limitations may not apply to you. The warranty covers specific legal rights which may vary by state, province and/or jurisdiction.

HOW TO OBTAIN WARRANTY SERVICE:

You must contact Customer Service at our toll-free number: 1-866-832-4843. A Customer Service Representative will attempt to resolve warranty issues over the phone. If the Customer Service Representative is unable to resolve the problem, you will be provided with a case number and asked to return the product to SENSIO Inc. Attach a tag to the product that includes: your name, address, daytime contact telephone number, case number, and description of the problem. Also, include a copy of the original sales receipt. Carefully package the tagged product with the sales receipt, and send it (with shipping and insurance prepaid) to SENSIO Inc.'s address. SENSIO Inc. shall bear no responsibility or liability for the returned product while in transit to SENSIO Inc.'s Customer Service Center.

CELEBRATE FRESH DISCOVER YOU LOVE LIFE
PLAYFUL BOLD ZUNE HAPPY



bellahousewares.com



BellaLife



BellaLife



BellaLifestyle



BellaLifestyle

For customer service questions or comments

1-866-832-4843

www.sensioinc.com

BELLA is a registered trademark of Sensio Inc., Montréal, Canada H3B 3X9.
All rights reserved.

SO-313494